

Three live video sources against Time of day timecode

TC Generator

00:00:00:00

Three XServe G5 CPUs, Running PictureReady for Record, and VirtualVTR for Playback, using Decklink Card for Output and AJA IOld for input. Each is a gigabit server so all systems can see all picture at all times.

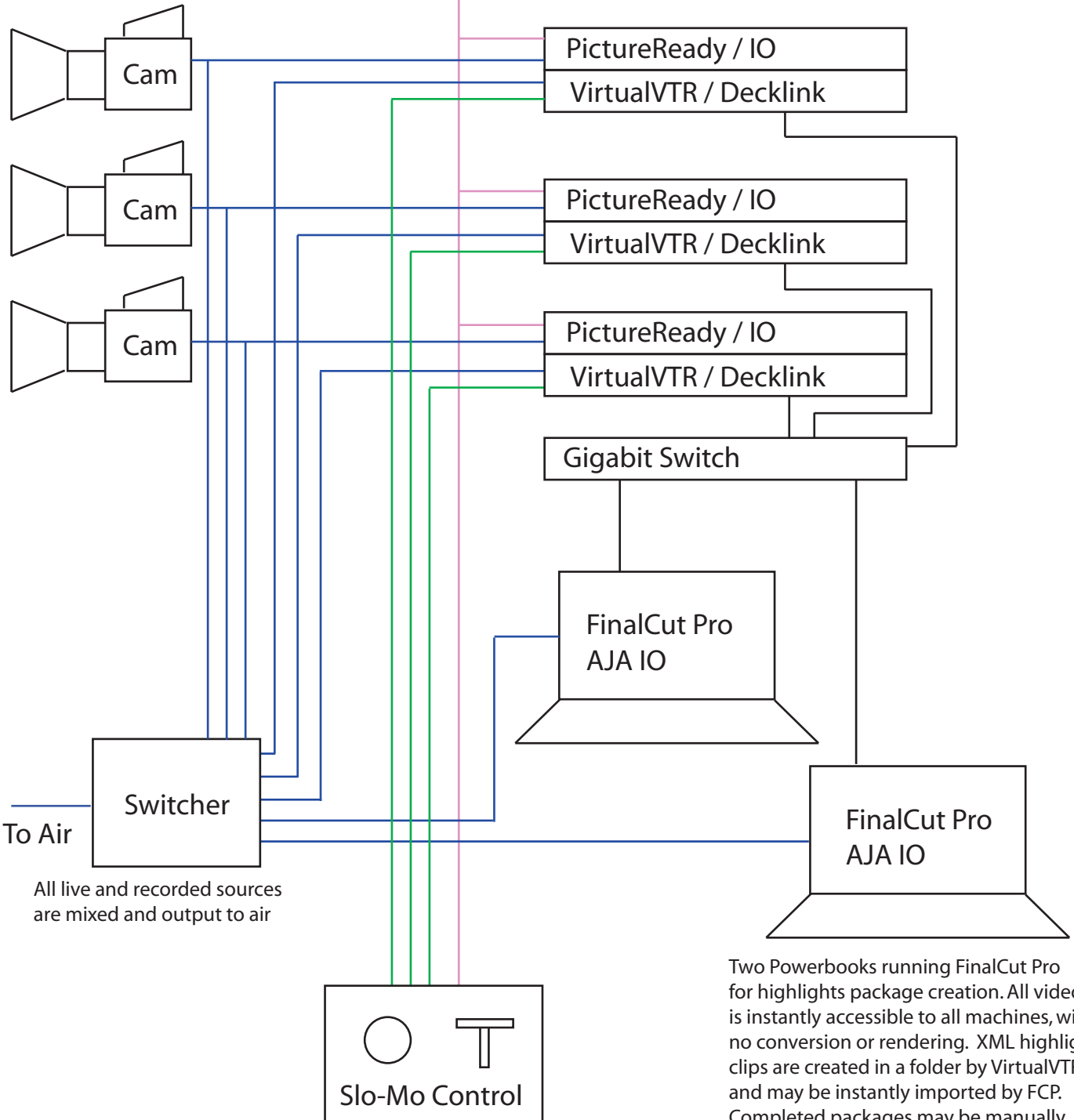

To Air

All live and recorded sources are mixed and output to air

Slo-Mo Control

DNF Slo-Mo interface controls playback of 3 video channels, with Odetics clip selection, perfect Slo-Mo replay. Also highlight points marked here are sent to VirtualVTR machines where they are converted into XML highlight clips for FC P

Two Powerbooks running FinalCut Pro for highlights package creation. All video is instantly accessible to all machines, with no conversion or rendering. XML highlight clips are created in a folder by VirtualVTR, and may be instantly imported by FCP. Completed packages may be manually cued for playback from FCP, or saved as QuickTime reference movies, then loaded as a new clip into a VirtualVTR player.

- Gigabit Ethernet
- Sony P2 Serial
- LTC Timecode
- SDI Video / Sound

Complete Sports WorkFlow  
3 Channel Record, 5 Playback  
©2004 Gallery UK